

A.1

STRENGTH

The ability of a material to stand up to forces being applied without it bending, breaking, shattering or deforming in any way.

ELASTICITY

The ability of a material to absorb force and flex in different directions, returning to its original position.

PLASTICITY

The ability of a material to be change in shape permanently.

MALLEABILITY

The ability of a material to be reshaped in all directions without cracking

1. Properties of Metals

DUCTILITY

The ability of a material to change shape (deform) usually by stretching along its length.

TOUGHNESS

A characteristic of a material that does not break or shatter when receiving a blow or under a sudden shock.

TENSILE STRENGTH

The ability of a material to stretch without breaking or snapping.

HARDNESS

The ability of a material to resist scratching, wear and tear and indentation.

CONDUCTIVITY

The ability of a material to conduct electricity.

Metals

2. An alloy is a metal (parent metal) combined with other substances (alloying agents), resulting in superior properties such as; strength, hardness, durability, ductility, tensile strength and toughness. The parent metal is the majority of the alloy. For example, mild steel is 0.1 - 0.3% Carbon and 99.9 - 99.7% Iron.

Metal lifecycle

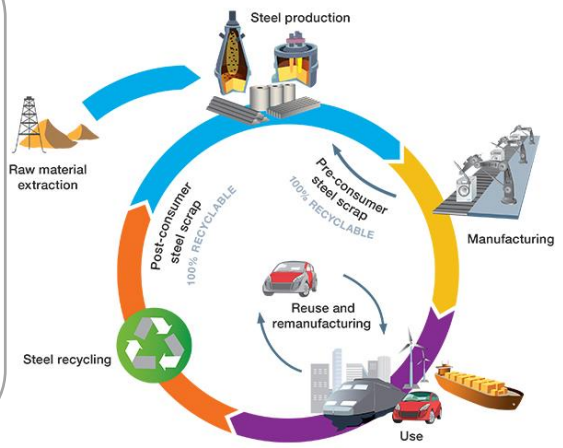

Metals are a **finite** resource that are extracted from the ground. Because of this, it is more important to recycle our waste metal. If we don't this could have a massive impact on our living world.

2. Ferrous Metals

Ferrous metals contain iron, and are known for their strength. Think steel, stainless steel, carbon steel, cast iron. Ferrous metals are used in both [architectural](#) and [industrial](#) fabrication, such as skyscrapers, bridges, vehicles, and railroads. Thanks to their magnetic properties, ferrous metals are also used in appliances and engines. Ferrous metals also have a high carbon content, which generally makes them prone to rust. The exceptions are stainless steel, because of chromium, and wrought iron because of its high pure iron content.

2. Non-Ferrous Metals

Non-ferrous metals have been used since the Copper Age, around 5,000 B.C. Since non-ferrous metals don't contain iron, they're usually more corrosion-resistant than ferrous metals. Some examples of non-ferrous metals are aluminium, aluminium alloys, and copper, which are often used in industrial applications such as gutters, roofing, pipes, and electrical. Non-ferrous metals also include brass, gold, nickel, silver, tin, lead, and zinc. Other common properties of non-ferrous metals are non-magnetic, malleable, and lightweight. This makes them ideal for use in aircraft and other applications.



Examples of ferrous metals are:

- Steel**: Iron plus carbon; widely used in construction and industrial metal fabrication
- Carbon steel**: Even higher carbon content added to iron; exceptionally hard metal
- Stainless steel**: An alloy steel made with added chromium,
- Cast iron**: Iron, carbon, silicon; heavy, hard metal that is resistant to wear



Oxyacetylene gas welding is commonly used to permanently join mild steel. A mixture of oxygen and acetylene, burns as an intense / focussed flame, at approximately 3,500 degrees centigrade. When the flame comes in contact with steel, it melts the surface forming a molten pool, allowing welding to take place. This type of welding is suitable for the prefabrication of steel sheet, tubes and plates.

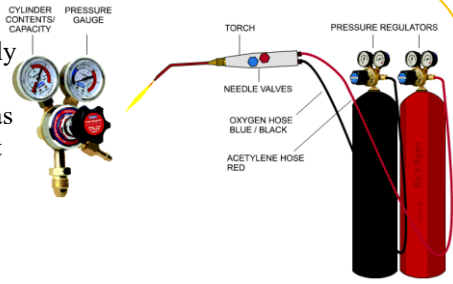

MIG welding. The electrode is a continuous stream of wire, with a direct current source, fed at a continuous rate through the welding gun. Carbon dioxide gas is supplied directly to the welding zone, which acts to protect the area from atmospheric contaminants. The wire electrode, produces an 'arc', which heats the welding area and fuses the wire electrode with the base metal (metal being welded). MIG welding is ideal for aluminium, mild steel, stainless steel, copper and copper alloys.

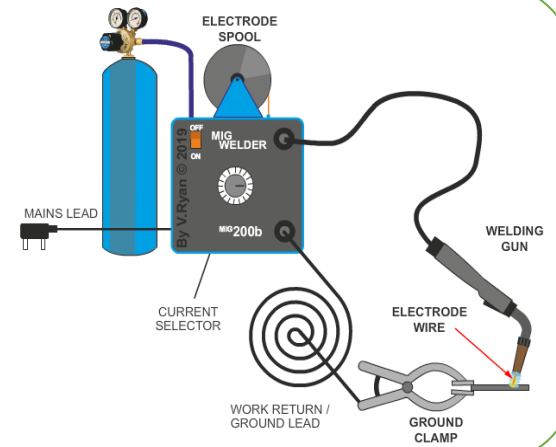

Processes

Metals

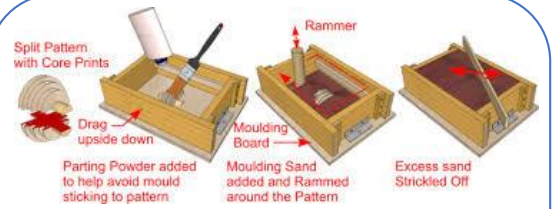

Sand casting is a process in which molten metal is poured into a mould cavity made by forming damp (i.e. **Green**) sand around a **Pattern**.

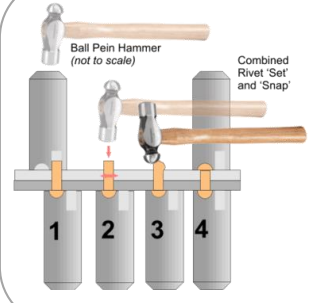

Rivets (aka Rivits) have various designs of head at one end and are used to fasten materials together by being passed through a punched or drilled hole and hammered over (*usually*) to form a head on the reverse side. They are available in several materials and sizes, can be solid or hollow and specialised designs also exist (e.g. 'Pop' Rivets).

Nuts and Bolts are available in a wide variety of sizes, types of screw thread, shapes of head and materials to provide a very commonly used means of fastening components together such that they can be removed if needed.



Stock Forms

SECTIONS - SOLIDS AND TUBES

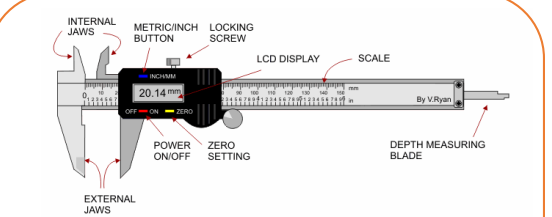
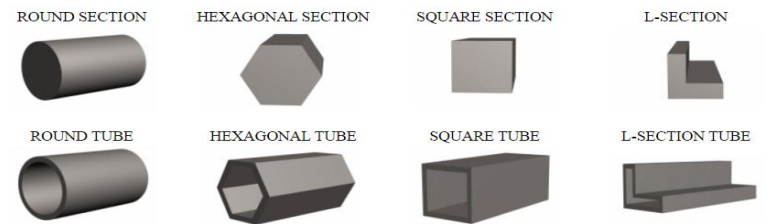

The Digital Caliper (sometimes incorrectly called the Digital Vernier Caliper) is a precision instrument that can be used to measure internal and external distances extremely accurately

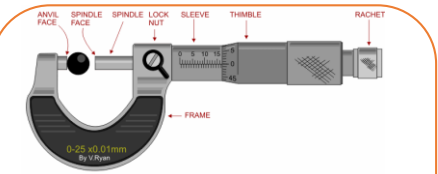

The Micrometer is a precision measuring instrument, used by engineers. Each revolution of the ratchet moves the spindle face 0.5mm towards the anvil face

Metal Finishes
These are needed not only to make the metal look nice, but more importantly to stop ferrous metals from corrosion.



YEAR 9. Design and Technology. Knowledge Organiser; Sustainability- Boards and Plastics.

Natural Plastics....

Natural sources of plastics include:

- plants - from which cellulose can be extracted
- trees - from which latex, amber and resin come
- animals - from which horn and milk (used to make glues) are obtained
- insects - from which shellac (used to make polish) is obtained

Synthetic

Synthetic plastics are chemically manufactured from:

-Crude oil..... -Coal..... -Natural gas



Polymer

The correct term for plastics is polymers. Most polymers are good insulators. Some of the stronger polymers compare favourably with metals. They are not normally painted, but their colour can be changed by adding pigments to them.

Most polymers are **made from oil**, which is a non-renewable resource. They are made by a chemical reaction called **polymerisation**.

There are two main types of polymer: **thermosets and thermoplastics**.

Thermosets are normally made into products by moulding. Once moulded, they cannot be reshaped and they cannot be recycled.

Thermoplastics soften when heated and can be shaped when hot. The shape will harden when it is cooled, but can be reshaped when heated up again. Thermoplastics are **softer and more flexible** than thermosets. They can normally be recycled

Fair trade

The result of the pattern of world trade is that the workers in primary industries in LEDCs often lose out. They receive low wages and often have poor standards of living. They cannot afford education for their children and many children are required to work to help their families earn a living.

Fair trade means that the producer receives a guaranteed and fair price for their product regardless of the price on the world market. This means their quality of life should improve, as well as the long-term prospects for their children.

Fair trade sets minimum standards for the pay and conditions of workers. The Fair Trade Organisation promotes Global Citizenship by guaranteeing a fair, minimum price for products. About 5 million people benefit from Fair Trade in 58 countries.

The life of the product

Electrical equipment awaiting recycling in a tip
Most products are only expected to last for so long before they stop working, are worn out or are thrown away. How long a product will last is an important design consideration. The longer the product's life, the fewer new materials will be needed for replacements. However, a longer life also means that the manufacturer will sell fewer replacement products.

The life of a product can be extended by using materials with better properties: eg by using stronger materials or materials that resist corrosion. Another way is through design that allows product life to be extended by maintenance

Acrylic .. Stiff and brittle. Used to make signs and small 2D and 3D forms

Polyvinyl sheet (PVC) Stiff, strong, tough and resists scratching. Used to make 2D and 3D shapes and may be used for vacuum-forming

High-density PVC foam..... Stiff, hard, tough and lightweight, with a good resistance to chemicals. Machining of 2D and 3D shapes

Polystyrene sheet (or styrene sheet) Lightweight, hard, stiff, transparent and brittle. Good water resistance. Used for vacuum-forming

Corrugated polypropylene Lightweight and tough. Stiff, but not very strong. Hard but scratches easily. Resistant to chemicals. Used for making large constructions

Acrylonitrile butadiene styrene (ABS) Strong, tough, hard, lightweight, and durable. A good surface finish and resistant to chemicals. Used to make square or round shaped tubes and is good for making structures. Corrugated polypropylene is available in a range of shapes and colours

Polystyrene foam (Styrofoam) Brittle in tension, lightweight, with good heat and sound insulation. Available in blocks and used for product-modelling

Cellophane Tough, hard, stiff, lightweight, transparent, and non-flammable. Used for wrapping round products

Polythene Hard, stiff and able to be sterilised. Used to make bottles and for shrink-wrapping products.



Social and moral issues

When creating a product, the designer should also consider how it will be made and how it will be used. Many of these decisions have implications for society as a whole and are based on moral judgements. This means that the designer has to be very aware of what is acceptable and what is not acceptable to society.

Environmental and social impact

Making products uses resources, including the materials used in the product and the energy needed to make it. Using these resources has an impact on the environment and society.

The designer of electronic products should consider a number of factors in order to reduce environmental impact, including:

- the material used to make the product
- the life of the product
- disposal: what happens to the product at the end of its life?

One-off production is when only one product is made at a time. Every product is different so it is labour intensive. Products may be made by hand or a combination of hand and machine methods.

Batch production is when a small quantity of identical products are made. Batch production may also be labour intensive, but jigs and templates are used to aid production. Batches of the product can be made as often as required. The machines can be easily changed to produce a batch of a different product.

Mass production is when hundreds of identical products are made, usually on a production line. Mass production often involves the assembly of a number of sub-assemblies of individual components. Parts may be bought from other companies. There is usually some automation of tasks (eg by using Computer Numerical Control machines) and this enables a smaller number of workers to output more products.

Continuous flow production is when many thousands of identical products are made. The difference between this and mass production is that the production line is kept running 24 hours a day, seven days a week to maximise production and eliminate the extra costs of starting and stopping the production process. The process is highly automated and few workers are required

Year 9 Knowledge Organiser... Mechanisms, Systems and Motions

Microcontrollers are widely used in everyday items such as washing machines, remote controls, microwave ovens, mobile phones and vending machines. A modern car can contain around 40 of them. Several different types are commonly used in school electronics projects, including PICs, PICAXE and GENIE microcontrollers.

Pulley systems

Pulleys are used to change the speed, direction of rotation, or turning force or torque.

A pulley system consists of two pulley wheels each on a shaft, connected by a belt. This transmits rotary motion and force from the input, or driver shaft, to the output, or driven shaft.

A pulley system with one 40mm diameter pulley and a 120mm pulley, connected by a belt. The smaller pulley is rotating at 100rpm

If the pulley wheels are different sizes, the smaller one will spin faster than the larger one. The difference in speed is called the velocity ratio.

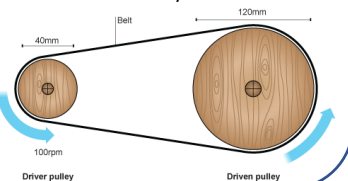

Types of Motions

	Linear Motion Motion in a straight line indefinitely.		Reciprocating Motion Back and forth motion. <i>Think, Pair share</i>
	Rotation Motion Motion in a circle.		Oscillating Motion Oscillation in a back and forth motion about a pivot point.
Task: Label the following pictures with the correct motion's			
Rotation	Oscillating	Reciprocating	Linear
Reciprocating	Oscillating	Rotating	Reciprocating
Action into Reciprocating	Reciprocating	Rotation and Reciprocating	Rotation

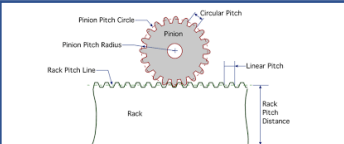

Rack and pinion

A pinion is a round cog and the rack is a flat bar with teeth. The driver cog either moves along the rack, as in a rack and pinion (funicular) railway - or else the driver cog moves the rack, as in the steering system in cars. Rack and pinion

changes rotary motion into linear motion.

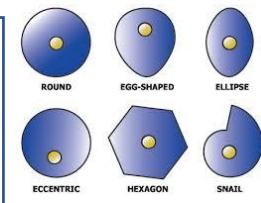

Types of motion
There are four basic types of motion in mechanical systems:
Rotary motion is turning round in a circle, such as a wheel turning.
Linear motion is moving in a straight line, such as on a paper trimmer.
Reciprocating motion is moving backwards and forwards in a straight line, as in cutting with a saw.
Oscillating motion is swinging from side to side, like a pendulum in a clock.
Many mechanisms take one type of input motion, and output it as a different type of motion.

Gears consist of toothed wheels fixed to shafts. The teeth interlock with each other, and as the first shaft (the driver shaft) rotates, the motion is transmitted to the second or driven shaft. The motion output at the driven shaft will be different from the motion input at the driver shaft - in place, speed, direction and other ways.
A number of gears connected together are called a gear train. The input (eg a motor) is connected to the driver gear. The output, (eg the wheel of a buggy) is connected to the driven gear.

MECHANISMS

WHAT IS A MECHANISM?
A machine is made up of a number of working parts called mechanisms. A mechanism changes an input force + movement into a desired output force + movement.

INPUT: Force + Movement going into a ...
MECHANISM: To convert or transmit energy to cause an ...
OUTPUT: Force + Movement to satisfy a need

SIMPLE MECHANISMS

- inclined plane:** These are the 5 simple mechanisms which form the basis of all machines.
- screw**
- wheel and axle**
- wedge**
- lever**

EXAMPLES OF MECHANISMS

- vice**
- lock**
- scissors**

Types of Gears

A gear is a wheel with teeth on its outer circumference connected to an axle. The teeth prevent slipping by engaging on another gear. The gear can be made to change direction, speed, and torque depending on its size, arrangement, and type.

- Worm Drive Gear:** Consists of a worm screw and worm wheel gear gears. The worm screw may have straight or angled teeth. The shafts lie in parallel planes and may be at any angle between 0 to 90°. The worm meshes with and turns the gear gear, but the gear doesn't turn the worm. **Advantage:** Operates silently. **Disadvantage:** Low efficiency due to heat production.
- Spur Gear:** The most common type. Straight teeth are parallel to the axis of the shaft. Used in most gears. Mounted in a series or parallel to each other. **Advantage:** Cost effective and highly reliable. **Disadvantage:** Cannot transfer power in opposite directions.
- Bevel Gear:** Two conical wheels that intersect teeth are parallel to the axis of the shaft. Used in high speed applications. The angle bevel creates inward contact with gear teeth. **Advantage:** Transmits motion and power between parallel and right angled shafts. **Disadvantage:** Generates heat.
- Helical Gear:** Teeth are inclined to the axis at an angle, usually 30°. Teeth are tapered in both thickness and length. Transmits power from one direction to another. Changes the direction of the shaft's rotation. **Advantage:** Able to change the operating angle. **Disadvantage:** Gears have to be matched to work.
- Rack & Pinion Gear:** Consists of a pinion gear with a rack. Both will turn in the same direction. **Advantage:** Converts rotational motion to linear motion. **Disadvantage:** High friction system.

Mechanical Systems

Linkages Connect Different Parts of a Mechanism

Levers can be connected together to form linkages. Simple linkages can change the magnitude of the force and the direction of motion. Here are two examples:

Push/Pull Linkages:

- 1) Push/pull linkages use two fixed pivots.
- 2) The input and output motions of the linkage are in the same direction. The motion of the link arm is in the opposite direction.
- 3) Here, each fixed pivot is in the centre of an arm. Changing the position of these pivots will change the magnitude of the output force — often the easiest way to see this is by making a model.

Bell Crank:

- 1) A bell crank changes the direction of a force through 90°.
- 2) The magnitude of the output force can be changed by moving the fixed pivot so it's not an equal distance between the two moving pivots.

Gear Trains Transmit or Change Rotary Motion

- 1) Gears are toothed wheels that interlock. They transfer motion from one part of a machine to another.
- 2) A gear train is where two or more gears are linked together. They can be used to change the direction of motion or change the magnitude of the input force (this is to do with the increase or decrease in the speed of rotation that can be generated by linking different-sized gears). Here are some examples:

Driver gear: turned by hand or a motor, turns the driven gear. Both will turn in opposite directions.

Idler: If you use a third gear (called an idler), the driver and the driven gears will both turn in the same direction. The size of the idler won't alter the speed of the other two gears.

If linked gears are different sizes, the smaller gear (i.e. the one with fewer teeth) will turn faster. The relationship between the driver and the driven gears can be described using a gear ratio. The size of this ratio describes how much the mechanism changes the speed of the gears from the input speed to the output speed. Here's an example of how gear ratios can be used in calculations:

EXAMPLE:

Gear ratio = $\frac{\text{no. of teeth on the driven gear}}{\text{no. of teeth on the driver gear}}$ Output speed = $\frac{\text{speed of driver gear (input speed)}}{\text{gear ratio}}$

A gear train is made up of a driver gear with 10 teeth and a driven gear with 20 teeth. The driver gear is rotating at 500 rpm (revolutions per minute). Calculate the output speed of the gear train.

Gear ratio = $20 \div 10 = 2/1$ or $2:1$ or 2 **Output speed = $500 \div 2 = 250$ rpm**

Type of paper and board.**Functional properties**

Layout paper	Light weight, thin white paper. It is used for initial ideas. It also take colour media well and it is also cheap.
Tracing paper	This is thin translucent paper. Which is used to make copies of drawings. However it is also quite expensive. Its made buy reducing the fibres concentration by prolonged beating in water.
Copier paper	Similar properties to cartridge paper. Its cheap when bought in bulk. The pulp is fed into the paper machine while the pulp is in the screen the water with in the pulp drops away letting the fibres bonded together.
Recycled paper	Made from reused paper products. Used for most documents including reports, memo paper and forms. This has a positive effect on the environment due to it being recycled
Corrugated board	Good impact resistance. It has a good strength for weight and is also recyclable. From the paper mill it is sent to the corrugating plant and then it is then glued between two more sheets of non corrugated card
Folding box board	Excellent for scoring, bending and creasing without splitting. It also is a excellent printing surface. Its made up of multiple layers of chemical and mechanical pulp.
Cartridge paper	This is good quality white paper which is available in different weights. Medium cost.
Mounting board	Good quality thick card which is used for final models and is used for mounting work.

The reason why cardboard is so popular is because it has several unique properties:

A sheet of corrugated cardboard is made out of three sheets of ordinary Kraft paper glued together with glue made of corn starch. Paper and glue are relatively inexpensive, so cardboard is inexpensive.

- Cardboard is completely recyclable and biodegradable.
- Cardboard is about half air, making it very light for its size.
- Compared to a sheet of paper, cardboard is incredibly rigid.
- Cardboard has some give, so it provides a little padding for the things inside the box.
- Cardboard is strong and resists punctures, but it is also easy to cut with a knife.
- When a box gets crushed it tends to stay together rather than shattering like wood would.
- Cardboard boxes fold flat for shipping without losing strength, making transportation much easier and less expensive. It is also very easy to put the boxes together.

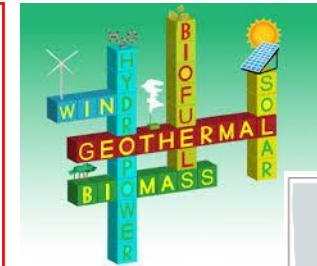
**A GUIDE TO PAPER WEIGHTS - GSM**

CAD/CAM (computer-aided design and computer-aided manufacturing) refers to computer software that is used to both design and manufacture products. **CAD** is the use of computer technology for design. We use 2D design. **CAD/CAM** applications are used to both design a product and program manufacturing processes. We use a Laser Cutter as a manufacturing machine.

1. Never Leave Your Laser Unattended When Firing
2. Never Cut Material with Unknown Properties
3. Always Keep A Clean Workshop
4. Be Informed
5. Be Alert

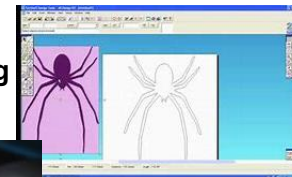

Computer Numerical Control
CNC means **Computer Numerical Control**. This means a computer converts the design produced by Computer Aided Design software (CAD), into numbers. The numbers can be considered to be the coordinates of a graph and they control the movement of the cutter.



Year 9 Knowledge Organiser... Electronics

Uses Of Electricity In Our Daily Life

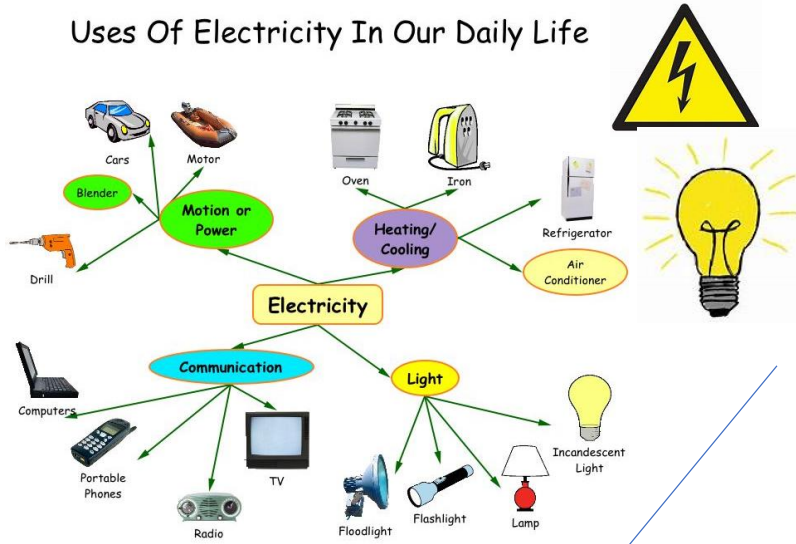

Electronics is the technology concerned with the design of circuits using transistors and microchips, and with the behaviour and movement of electrons.

There are many different types of electrical and electronic components, including resistors, capacitors and diodes. Each of these has a specific use in a circuit.

Discrete electronic components
Discrete (meaning separate) electronic components can be selected individually and put together to make a circuit. Examples of discrete components include resistors, capacitors, diodes and transistors.

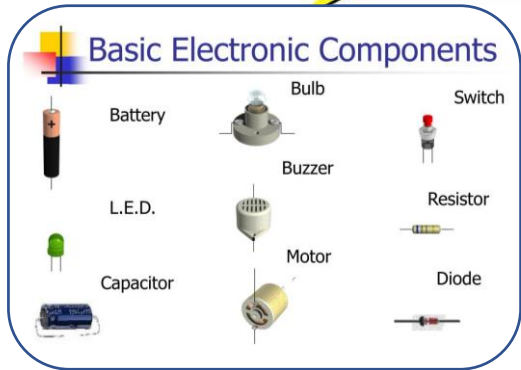

There are many different types of electrical and electronic components, including resistors, capacitors and diodes. Each of these has a specific use in a circuit.

Components
Electronic components can be divided into two groups: discrete electronic components and integrated circuits (ICs).

Discrete electronic components
Discrete (meaning separate) electronic components can be selected individually and put together to make a circuit. Examples of discrete components include resistors, capacitors, diodes and transistors. Discrete components can also be used as components in circuits that include an integrated circuit.

Integrated circuits
The circuits inside integrated circuits are arranged in different configurations depending upon the type of chip and its function. The most common type of configuration is called the dual-in-line or DIL package, which has two rows of connecting 'legs', one on each side. You don't need to understand how the circuit inside a silicon chip works. It's best to think of ICs simply in terms of their function: eg as timers, counters, logic gates or operational amplifiers (op-amps).

- When using ICs you need to know:
- which pins have to be connected
 - the function of each pin
 - how the IC is connected to the power supply

Resistor colour code

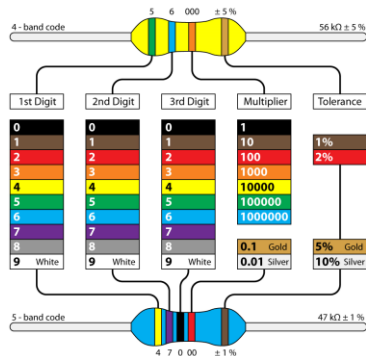

Soldering is a process in which two or more items (usually metal) are joined together by melting and putting a filler metal-solder into the joint. The filler metal having a lower melting point than the joining metal.



CAD is not only used to design and manufacture products. It is also used to create circuits for use in electronics.

